

## Accessories

### Installation Instructions

#### Topguard, Topguard Plain and Tyreguard Primary Barrier Matting Data Sheet: Page 1 of 2 14.01.22

These instructions apply to Topguard, Topguard Plain and Tyreguard mats.

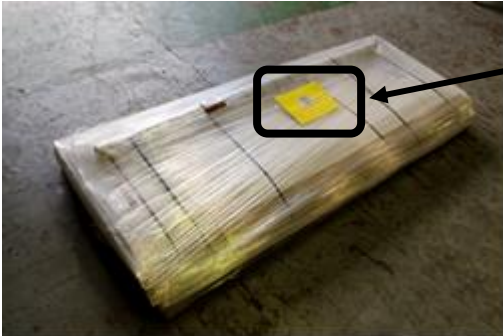

Open the packaging carefully and look for the "Matting order confirmation form" (yellow envelope). Check the contents are complete as per the delivery note.

Each mat panel is labelled, as shown in the "Matting order confirmation form".

Locate the "T" shaped divider bars and any perimeter pvc edge trims.

Before commencing the mat installation, the matwell preparation should be completed with the subfloor flat, dry and free from contaminants. Also check the perimeter frame is level and suitable to install the gauge of entrance mat supplied.

Irregularities in the matwell substrate should be made good prior to mat installation to avoid premature wear or damage to the mat during use.

Check any door opening clearance is suitable to accept the entrance mat.

Check that each panel is clearly marked, and matches the details shown on the "Matting order confirmation form" before any installation commences. Where possible, prior to installation, lay the matting panels out in an adjacent clean, dry area to check the panels fit together correctly and match the plan supplied.

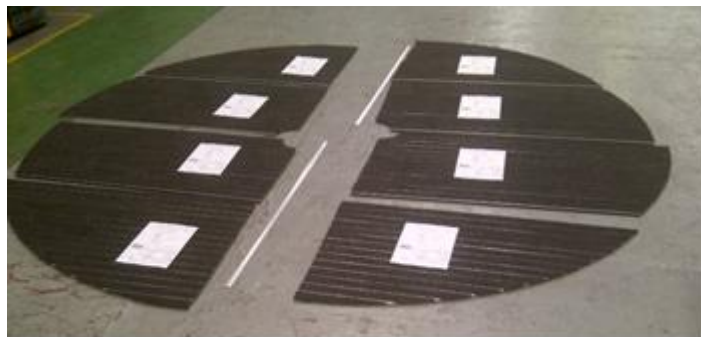

Mats produced to a drawing or template are supplied to a finished size, as requested, and indicated on the "Matting order confirmation form" and should require minimal site adjustment. The mats should then be laid so that the pedestrians walk across the mat ribs, direction of traffic (DOT), and not along them.

Mats exceeding 2m wide may be supplied with divider bars. When provided for installation they must be placed between panel sections and along the direction of travel (DOT) prior to the fitting of the matting panels.

Highlighted on the "Matting order confirmation form" are the locations to fit divider bars. Divider bars should be installed to provide a 1mm clearance to ensure the matting panel can be cleanly dropped into position.

The divider bars are fitted into the prepared matwell base using either double sided tape or gunned adhesive. Ensure the top edges of the divider bars are flush with the top of the matwell frame.

Check the front to back clearance in the direction of traffic (DOT). Topguard and Tyreguard mats are normally supplied in finished panel sizes which should ensure they can be installed without any need for on-site alterations. Where any fitting adjustments are considered necessary, this should then be carried out by a competent fitter as the affected module(s) will require re-tensioning and the stabiliser wires recut and closed off.

### Installation Instructions

---

**Topguard, Topguard Plain and Tyreguard Primary Barrier Matting** Data Sheet: Page 2 of 2 14.01.22

**Topguard 12mm open construction with double grey nylon wipers recessed in a matwell**

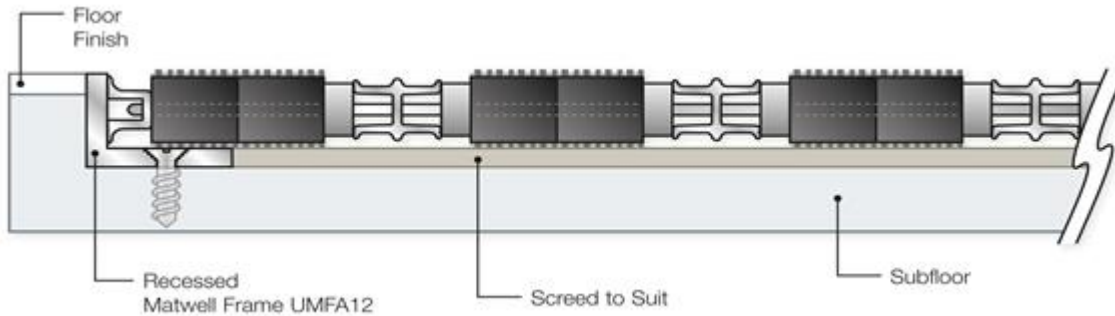

Commence installation with an unshaped mat panel wherever possible, being sure to follow the location indicated in the "Matting order confirmation form". Further panels should then be fitted, ensuring all panels are tight to the divider bars and with no gaps, except for a 1mm tolerance. When fitted correctly, the adjacent panels either side of the divider bars should align.

Leave the labels on each mat panel, until the installation is completed.

When fitted correctly, adjacent panels either side of the divider bars should then align.